

#Jenny



Finally I get this ebook, thanks for all these I can get now!

#Rio



Cool! I'am really happy

#Markus Jensen



I did not think that this would work, my best friend showed me this website, and it does! I get my most wanted eBook

#Hun Tsu



wtf this great ebook for free?!

#Che Salsa



My friends are so mad that they do not know how I have all the high quality ebook which they do not!

#Diego Butler



so many fake sites. this is the first one which worked! Many thanks

ENGINE

7. Compress the valve spring by hand using valve spring compressor adapter (P/N42513-A). Compress spring only enough to allow split keeper installation.

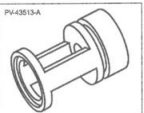

NOTE: To prevent damage to the valve seats, do not compress the valve spring more than necessary to install the keepers.

8. Install split keepers (E) with gap even on both sides.

9. Repeat this procedure for remaining valves.

10. Exercise each valve through its travel to ensure the valve keepers are seated correctly.

11. Install the valve support (H) for each valve in the order they were removed.



NOTE: If any valve train components were replaced, refer to "Valve Clearance Adjustment" procedure prior to "Camshaft Installation / Timing" procedure.

Valve Sealing Test

1. Clean and dry the combustion chamber area (A).
2. Pour a small amount of clean solvent into each intake port (B) and check for leakage around the valves. The valve seats should hold fluid with no seepage.
3. Repeat for exhaust valves by pouring fluid into each exhaust port (C).

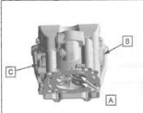

Cylinder Head Installation

NOTE: Head gasket and surface must be DRY and oil free. Use care during assembly to keep oil and finger prints off of gasket.

1. Prepare cylinder head gasket sealing surfaces by cleaning thoroughly to remove all residue. The new head gasket must be installed clean and dry, free from oil or grease.
2. Do not touch sealing surfaces of the new head gasket.
3. Guide cam chain (D) through a new head gasket (E) and install the gasket on the cylinder, seating it on the alignment pins.
4. Carefully set the cylinder head (F) in place on alignment pins.
5. Install and finger tighten the (4) new cylinder head bolts.
6. Install and finger tighten the (2) new outer MI bolts (H) evenly.

NOTE: Install new cylinder head bolts.

NOTE: Install and finger tighten the (4) new cylinder head bolts (G) evenly.

NOTE: Install and finger tighten the (2) new outer MI bolts (H) evenly.

3.59

1698767-2014 Ranger 570 Service Manual
© Copyright 2013 Polaris Inc.

[Download PDF version of :](#)
2014 Polaris Ranger 570 Crew Service Manual